

SPECIFICATION

VER. 1.9

ANMG08 (8-CH Auto Sensitivity Calibration Capacitive Touch Sensor)

General

The ANMG08 is 8-Channel capacitive sensor with auto sensitivity calibration. And the supply voltage range is from 3.0 to 5.5V.

The ANMG08 offers LED drivers with 16 steps dimming controller. The D[1:8] ports can be used for PWM output for LED dimming control.

The result of touch sensing can be checked by two kind of interface. One is parallel output port(D[1:8]). D[1:8] is touch sensing result of CS[1:8]. The other is I²C serial interface. I²C interface might be useful when the MCU IO or connector resource is not enough in the application.

The ANMG08 has SCL and SDA for I²C interface. SCL is I²C clock input pin and SDA is I²C data input-output pin. These ports have internal pull-up resistor(32KΩ).

In case of not use, this pin must be not connected to any circuitry.

Feature

- 8-Channel capacitive sensor with auto sensitivity calibration
- Available LED PWM drive up to 8
- Multi interface - I²C serial interface / Parallel outputs
- Selectable output operation mode (Single output / Multi output)
- Adjustable 256 steps sensitivity
- Almost no external component needed
- Low current consumption
- Embedded common and normal noise elimination circuit
- RoHS compliant 24SSOP packages
- Moisture sensitivity level 3 (MSL3)
- 3.0V to 5.5V operation
- Power consumption
 - Standby state : 0.50mA (@3.3V)

Block Diagram

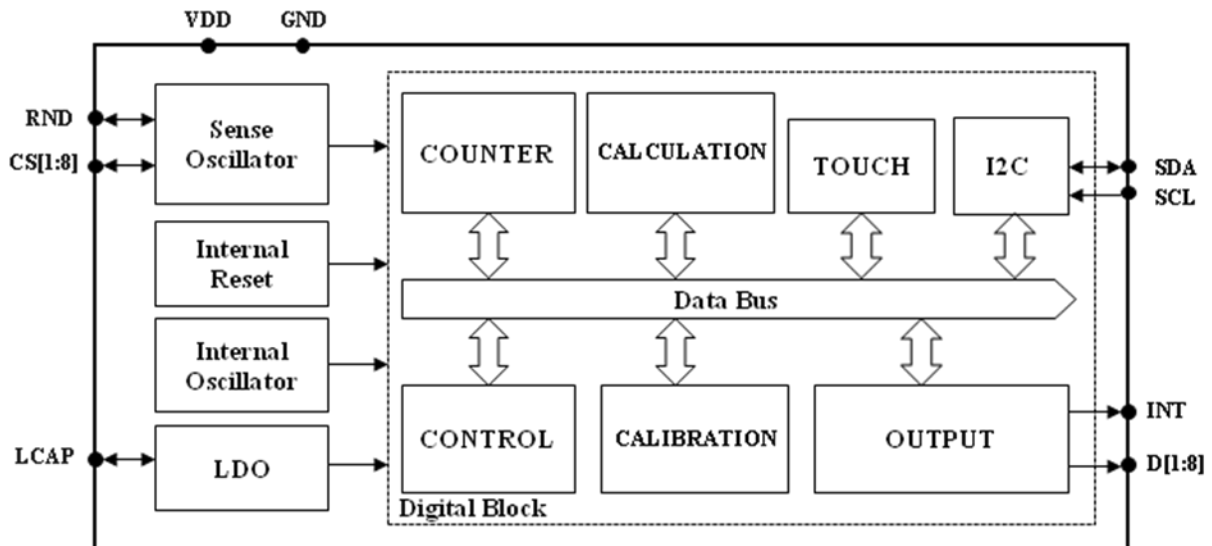

Application

- Multimedia Devices(TV, DVD player, Blu-ray player, Digital photo frame, Home theater system)
- Home Appliance(Refrigerator, Air cleaner, Air conditioner, Washing machine, Microwave oven)
- Sealed control panels, keypads

Ordering Information

Part No.	Package
ANMG08PL	24SSOP

■ Revision History

Rev.	Description of change	Date	Originator
1.0	First creation	13. 10. 10.	KD PARK
1.1	Revise the unit in the POD	13. 12. 06.	KD PARK
1.2	Revise the Latch-up Level Correct the sentence : "Battery Supply voltage" -> "Maximum supply voltage"	14. 05. 21.	KD PARK
1.3	Revise the operating voltage	14. 08. 11.	HS KWAK
1.4	Revise the Reset voltage	14. 09. 16.	HS KWAK
1.5	Revise recommended circuit guide about reset operation	15. 03. 16.	HS KWAK
1.6	Revise recommended circuit(Application Example Circuit)	15. 04. 23.	HS KWAK
1.7	Add the package code of IC (ANMG08 -> ANMG08PL)	15. 11. 12.	HS KWAK
1.8	Revise recommended circuit(Application Example Circuit)	16. 04. 21.	HS KWAK
1.9	Add general features page, Ordering Information I2C Register map partial modification	16. 10. 10.	HS KWAK

Content

General.....	2
■ Revision History	3
1 Pin Configuration	5
2 Pin Description	6
2.1 Pin Map (24SSOP package)	7
3 Absolute Maximum Rating	8
4 ESD & Latch-up Characteristics	8
4.1 ESD Characteristics	8
4.2 Latch-up Characteristics	8
5 Electrical Characteristics	9
6 ANMG08 Implementation.....	10
6.1 Typical current consumption	10
6.2 CS implementation	10
6.3 LED drive implementation	11
6.4 Parallel output	11
6.5 INT (Interrupt output) Implementation	11
6.6 SCL, SDA implementation.....	12
7 I ² C Interface.....	13
7.1 I ² C Enable / Disable.....	13
7.2 Start & stop condition.....	13
7.3 Data validity.....	13
7.4 Byte format	13
7.5 Acknowledge	13
7.6 First byte	14
7.7 Transferring data.....	15
7.8 I ² C write and read operations in normal mode	16
7.9 I ² C timing diagram	16
8 ANMG08 control register list.....	17
8.1 I ² C Register Map	17
8.2 Details	18
9 Recommended Circuit Diagram	25
9.1 ANMG08PL (24 SSOP)	25
10 MECHANICAL DRAWING	27
10.1 Mechanical Drawing of ANMG08PL (24 SSOP)	27
11 MARKING DESCRIPTION	28
11.1 Marking Description of ANMG08PL (24 SSOP)	28
NOTES:	29

1 Pin Configuration

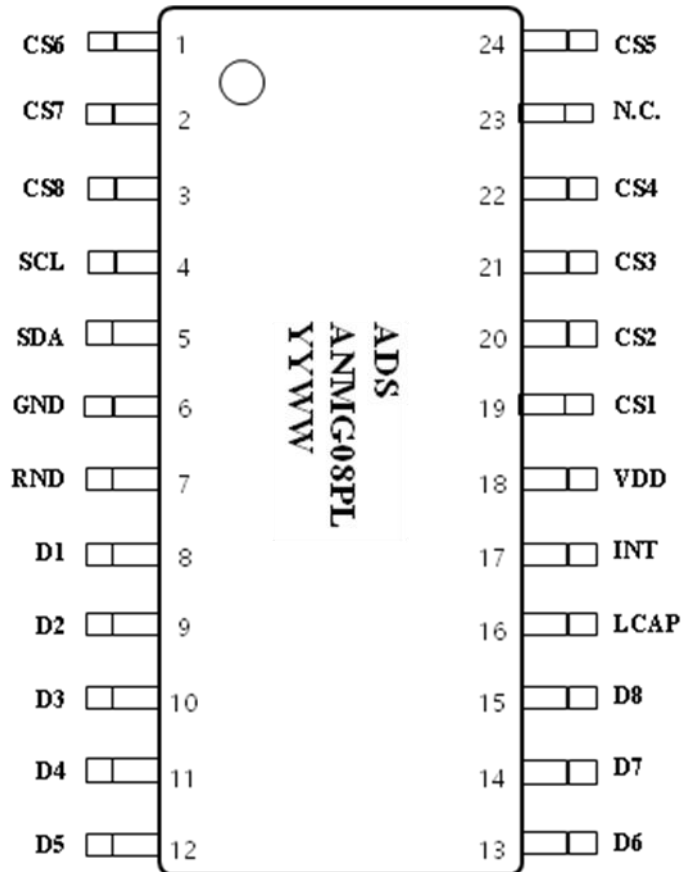

ANMG08PL (24-SSOP)

2 Pin Description

VDD, GND

Supply voltage and ground pin.

R.N.D

Radio frequency Noise Detection pin. Normally, R.N.D pin does not connect to anywhere.

But, in radio frequency noise environment, this pin must form a pattern line on PCB.

CS1 ~ CS8

Capacitive sensor input pins.

LCAP

Internal LDO output port.

D1 ~ D8

Parallel output ports of CS1~CS8 respectively / LED PWM drive output ports. The structure of these parallel output ports is open drain NMOS for active low output level operation.

SCL, SDA

SCL is I²C clock input pin and SDA is I²C data input-output pin. These ports have internal pull-up resistor.

In case of not use, this pin must be not connected to any circuitry.

INT

Touch sensing interrupt output pin. This port has internal pull-up resistor.

ANMG08 (8-CH Auto Sensitivity Calibration Capacitive Touch Sensor)

2.1 Pin Map (24SSOP package)

Pin Number	Name	I/O	Description	Protection
1	CS6	Analog Input	Capacitive sensor input 6	VDD/GND
2	CS7	Analog Input	Capacitive sensor input 7	VDD/GND
3	CS8	Analog Input	Capacitive sensor input 8	VDD/GND
4	SCL	Digital Input	I ² C clock input	VDD/GND
5	SDA	Digital Input / Output	I ² C data input-output Open drain NMOS structure	VDD/GND
6	GND	Ground	Supply ground	VDD
7	R.N.D	Analog Input	Radio frequency Noise Detection pin	VDD/GND
8	D1	Digital Output	Parallel output of CS1 LED PWM drive output1 Open drain NMOS structure	VDD/GND
9	D2	Digital Output	Parallel output of CS2 LED PWM drive output2 Open drain NMOS structure	VDD/GND
10	D3	Digital Output	Parallel output of CS3 LED PWM drive output3 Open drain NMOS structure	VDD/GND
11	D4	Digital Output	Parallel output of CS4 LED PWM drive output4 Open drain NMOS structure	VDD/GND
12	D5	Digital Output	Parallel output of CS5 LED PWM drive output5 Open drain NMOS structure	VDD/GND
13	D6	Digital Output	Parallel output of CS6 LED PWM drive output6 Open drain NMOS structure	VDD/GND
14	D7	Digital Output	Parallel output of CS7 LED PWM drive output7 Open drain NMOS structure	VDD/GND
15	D8	Digital Output	Parallel output of CS8 LED PWM drive output8 Open drain NMOS structure	VDD/GND
16	LCAP	Analog Output	Internal LDO Output	VDD/GND
17	INT	Digital Output	Touch sensing interrupt output Open drain NMOS structure	VDD/GND
18	VDD	Power	Power (3.0V~5.5V)	GND
19	CS1	Analog Input	Capacitive sensor input 1	VDD/GND
20	CS2	Analog Input	Capacitive sensor input 2	VDD/GND
21	CS3	Analog Input	Capacitive sensor input 3	VDD/GND
22	CS4	Analog Input	Capacitive sensor input 4	VDD/GND
23	N.C.	-	-	-
24	CS5	Analog Input	Capacitive sensor input 5	VDD/GND

ANMG08 (8-CH Auto Sensitivity Calibration Capacitive Touch Sensor)

3 Absolute Maximum Rating

Maximum supply voltage	5.5V
Maximum voltage on any pin	VDD+0.3
Maximum current on any PAD	100mA
Power Dissipation	800mW
Storage Temperature	-50 ~ 150 °C
Operating Temperature	-20 ~ 75 °C
Junction Temperature	150 °C

Note : Unless any other command is noted, all above are operated in normal temperature.

4 ESD & Latch-up Characteristics

4.1 ESD Characteristics

Mode	Polarity	Max	Reference
H.B.M	Pos / Neg	8000V	VDD
		8000V	VSS
		8000V	P to P
M.M	Pos / Neg	550V	VDD
		550V	VSS
		400V	P to P
C.D.M	-	800V	Field Induced Charge

4.2 Latch-up Characteristics

Mode	Polarity	Max	Reference
I Test	Positive	200mA	JESD78D : 2011
	Negative	200mA	
V supply over 5.0V	Positive	8.25V	

ANMG08 (8-CH Auto Sensitivity Calibration Capacitive Touch Sensor)

5 Electrical Characteristics

▪ $V_{DD}=3.3V$, Typical system frequency (Unless otherwise noted), $T_A = 25^\circ C$

Characteristics	Symbol	Test Condition	Min	Typ	Max	Units
Power supply requirement and current consumption						
Operating voltage	V_{DD}		3.0		5.5	V
Current consumption	I_{DD}	$V_{DD}= 3.3V$, Standby state	-	0.50	-	mA
Reset and input level						
Internal reset voltage	V_{DD_RST}	$T_A = 25^\circ C$	-	2.6	-	V
Input high level	V_{IH}	$ I_{IH} \leq +5\mu A$	$V_{DD} * 0.6$		$V_{DD} + 0.3$	V
Input low level	V_{IL}	$ I_{IL} \leq +5\mu A$	-0.3		$V_{DD} * 0.3$	V
Self calibration time after system reset	T_{CAL}	Slow calibration speed	-	100	-	msec
		Normal calibration speed	-	80	-	
		Fast calibration speed	-	60	-	
Internal Pull Up resistor of SDA, SCL, INT	$R_{P/U}$		-	30	-	k Ω
Touch sensing performance						
Minimum detectable capacitance difference	ΔC_{MIN}		0.1	-	-	pF
Sense input capacitance range ¹	C_S		-	-	50	pF
Output impedance (open drain)	Z_O	$\Delta C > \Delta C_{MIN}$	-	12	-	Ω
		$\Delta C < \Delta C_{MIN}$	-	30M	-	
System performance						
Max. output current (LED drive current)	I_{OUT}	Per unit drive output port	-	-	8.0	mA
LED PWM control ²	N_{PWM}		-	16	-	step
Sensitivity control ³			-	256	-	step
Max. I ² C SCL clock speed	f_{SCL_MAX}	Maximum internal I ² C clock	-	-	2	MHz
Touch expired time	T_{EX}	Normal calibration speed	-	30	-	sec

¹ The sensitivity can be decreased with higher parallel capacitance of CS pin including parasitic capacitance made by neighbor GND or other pattern. The series resistor(under 1k Ω) of CS can be used in noisy condition to avoid mal-function from external surge and ESD.

² Refer to the chapter 8.2.11. LED luminance control register

³ Refer to the chapter 8.2.8. Sensitivity register

6 ANMG08 Implementation

6.1 Typical current consumption

ANMG08 uses internal bias circuit, so internal clock frequency and current consumption is fixed and no external bias circuit is needed. Internal clock frequency and calibration speed can be changed by I²C register setting⁴. Faster calibration speed needs more current consumption than normal or slower calibration speed. Slow calibration speed isn't recommended if it has not problem of current consumption.

Internal bias circuit can make the circuit design simple and reduce external components.

6.2 CS implementation

ANMG08 has 256 step selections of sensitivity and internal surge protection resistor. Sensitivity of each sensing channel (CS) can be independently controlled on others. External components of CS pin such as series resistor or parallel capacitor isn't necessary. The parallel parasitic capacitance of CS pins caused by touch line, touch pad and neighbor GND or other pattern may affect sensitivity. The sensitivity will be decreased when bigger parallel parasitic capacitance of CS pin is added.

Parallel capacitor (C_{S1~S8}) of CS pin is useful in case of detail sensitivity mediation is required such as for complementation sensitivity difference between channels. Same as above parallel parasitic capacitance, sensitivity will be decreased when a big value of parallel capacitor (C_{S1~S8}) is used. Under 50pF capacitor can be used as sensitivity meditation capacitor and a few pF is usually used. The R_S, serial connection resistor of CS pins, may be used to avoid mal-function from external surge and ESD. (It might be optional.) From 200Ω to 1kΩ is recommended for R_S. Refer to below CS pins application figure.

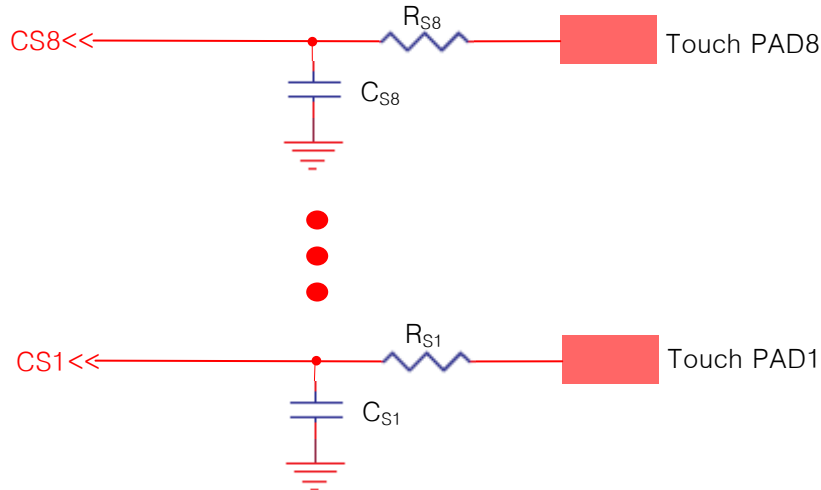

The ANMG08 has eight independent touch sensor input from CS1 to CS8. The internal touch decision process of each channel is separated from others. Therefore eight channel touch key board application can be designed by using only one ANMG08 without coupling problems.

The size and shape of PAD might have influence on the sensitivity. The sensitivity will be optimal when the size of PAD is approximately an half of the first knuckle (it's about 10 mm x 7 mm). The connection line of CS to touch PAD is recommended to be routed as short as possible to prevent from abnormal touch detect caused by connection line. The unused CS pin should not be connected with the ground. The unused CS pin(Channel) should be disable⁵ or open.

⁴ Refer to 8.2.4. Clock control register.

⁵ Refer to 8.2.1 Channel enable / reset register

ANMG08 (8-CH Auto Sensitivity Calibration Capacitive Touch Sensor)

6.3 LED drive implementation

ANMG08 has a function to control the LED using D1~D8 ports. For using D1~D8 as LED driver ports, LEDs and resistors must be equipped as below figure, and write the 'port_mode' register⁶ as '1'. D1 ~ D8 ports can drive LEDs by 'PWM_ctrlx' register⁷ control. ANMG08 can drive up to 8 LED as below method. The unused Dx port should not be open. The unused Dx port should be connected with VDD or GND.

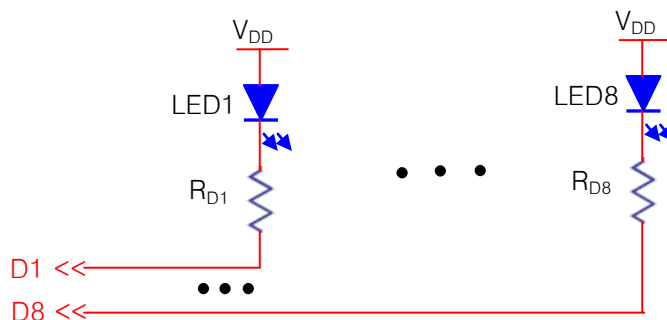

6.4 Parallel output

ANMG08 acts as active low parallel output mode. Parallel output ports (D1~D8) have an open drain NMOS structure. For this reason, the parallel output mode of ANMG08 needs R_{OUT} as below figures. The maximum output drive current is 8mA, so over a few kΩ must be used as R_{OUT}. Normally 10kΩ is used as R_{OUT}. The unused Dx port should not be open. The unused Dx port should be connected with VDD or GND.

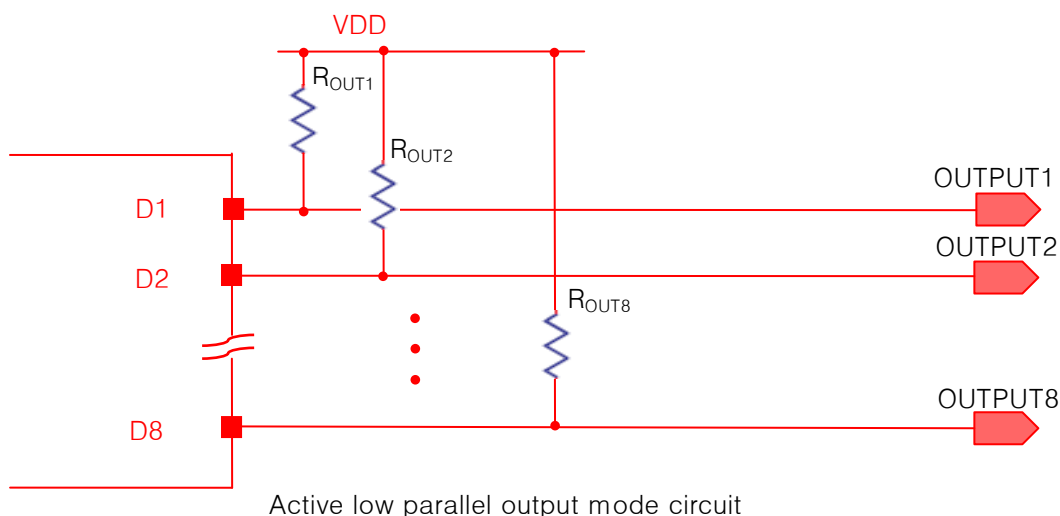

6.5 INT (Interrupt output) Implementation

An INT pin is for the touch sensing interrupt output. The interrupt pulse is generated only during short period of every each channel touch start point and touch end point. Interrupt pulse has logical low level. INT has NMOS open drain structure and internal pull-up resistor of which value is 30kΩ typical.

⁶ Refer to the chapter 8.2.12. Port mode control register

⁷ Refer to the chapter 8.2.11. LED luminance control register

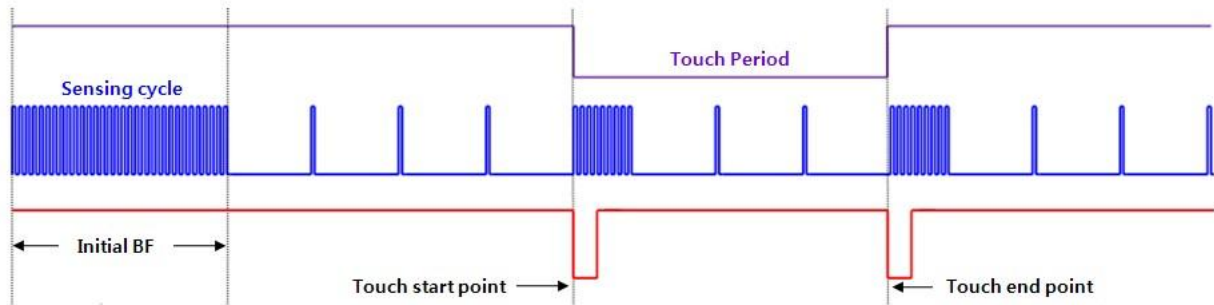

6.6 SCL, SDA implementation

SCL is I²C clock input and SDA is I²C data input-output. These ports have internal pull-up resistor. SCL has Schmitt trigger input structure to prevent clock signal from being broken. Maximum supported I²C clock frequency is 2MHz. SDA has NMOS open drain structure and internal pull-up resistor of which value is 30k Ω typical. So, according to communication speed a few k Ω resistor must be used as pull-up resistor for proper data pulse rising time. For more details refer to 'Chapter 9. I²C Interface'.

7 I²C Interface

7.1 I²C Enable / Disable

If the SDA or SCL signal goes low, I²C control block is enabled automatically. And if the SDA and SCL signal maintain high during about 2 us, I²C control block is disabled automatically also.

7.2 Start & stop condition

- ◀ Start Condition (S)
- ◀ Stop Condition (P)
- ◀ Repeated Start (Sr)

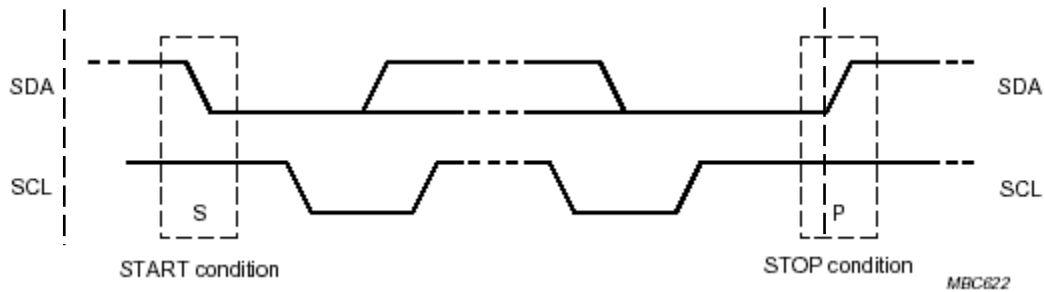

7.3 Data validity

The SDA should be stable when the SCL is high and the SDA can be changed when the SCL is low.

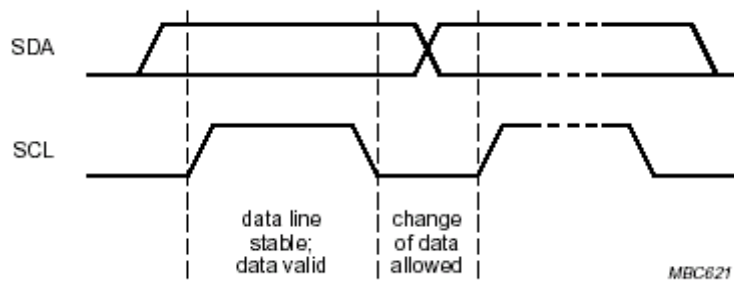

7.4 Byte format

The byte structure is composed with 8Bit data and an acknowledge signal.

7.5 Acknowledge

It is a check bit whether the receiver gets the data from the transmitter without error or not. The receiver will write '0' when it received the data successfully and '1' if not.

ANMG08 (8-CH Auto Sensitivity Calibration Capacitive Touch Sensor)

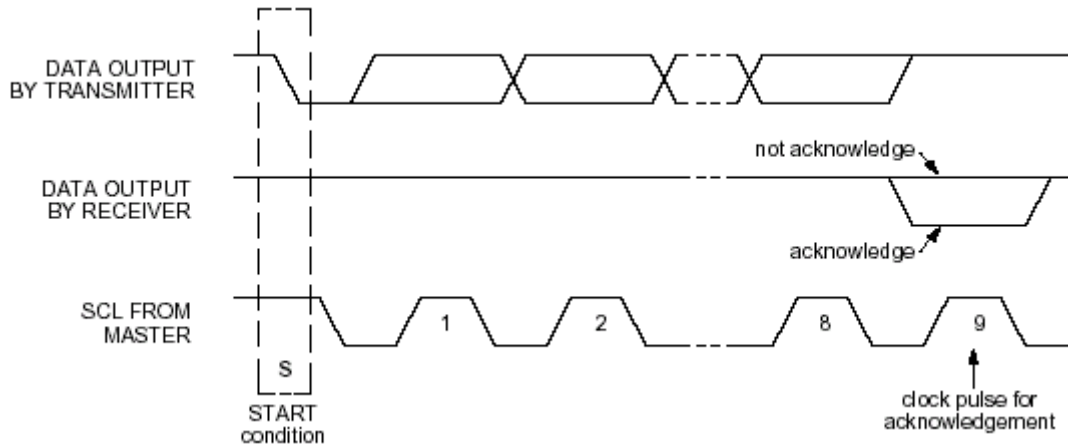

7.6 First byte

7.6.1 Slave address

It is the first byte from the start condition. It is used to access the slave device. The initial chip address of ANMG08 is '48' hexadecimal number.

7.6.2 R/W

The direction of data is decided by the bit and it follows the address data.

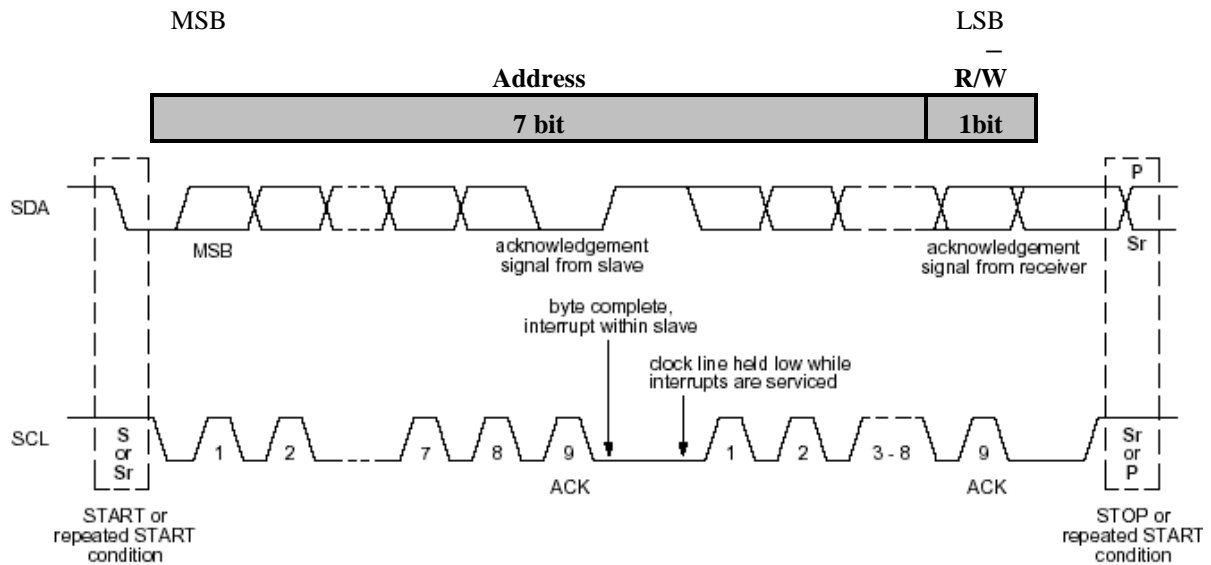

ANMG08 (8-CH Auto Sensitivity Calibration Capacitive Touch Sensor)

7.7 Transferring data

7.7.1 Write operation

The byte sequence is as follows:

1. The first byte gives the device address plus the direction bit (R/W = 0).
2. The second byte contains the internal address of the first register to be accessed.
3. The next byte is written in the internal register. Following bytes are written in successive internal registers.
4. The transfer lasts until stop conditions are encountered.
5. The ANMG08 acknowledges every byte transfer.

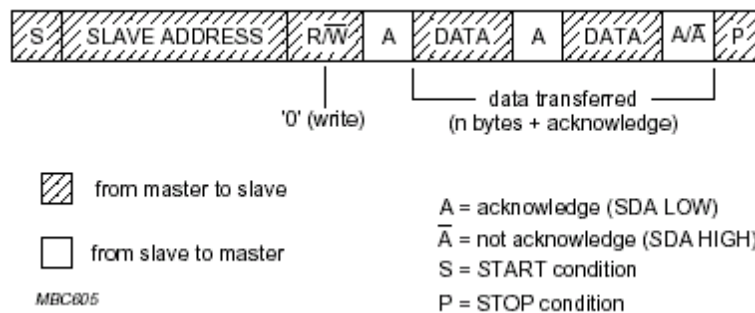

7.7.2 Read operation

The address of the first register to read is programmed in a write operation without data, and terminated by the stop condition. Then, another start is followed by the device address and R/W= 1. All following bytes are now data to be read at successive positions starting from the initial address.

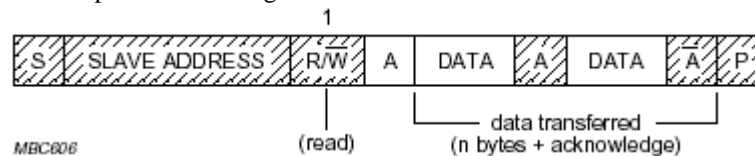

7.7.3 Read/Write Operation

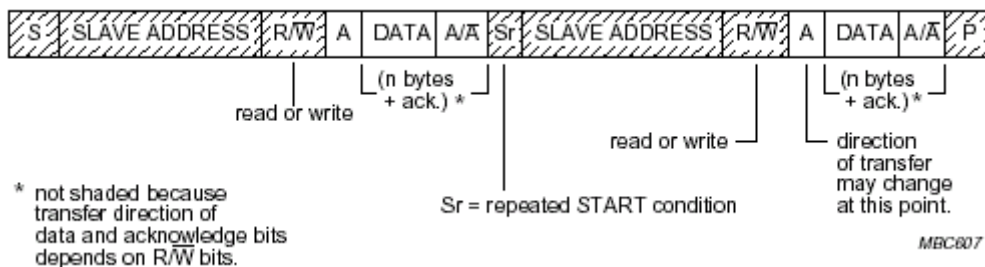

ANMG08 (8-CH Auto Sensitivity Calibration Capacitive Touch Sensor)

7.8 I²C write and read operations in normal mode

The following figure represents the I²C normal mode write and read registers.

☞ Write register 0x00 to 0x01 with data AA and BB

Start	Device Address 0x48	ACK	Register Address 0x00	ACK	Data AA	ACK	Data BB	ACK	Stop
-------	---------------------	-----	-----------------------	-----	---------	-----	---------	-----	------

Read register 0x00 and 0x01

Start	Device Address 0x48	ACK	Register Address 0x00	ACK	Stop
-------	---------------------	-----	-----------------------	-----	------

Start	Device Address 0x49	ACK	Data Read AA	ACK	Data Read BB	ACK	Stop
-------	---------------------	-----	--------------	-----	--------------	-----	------

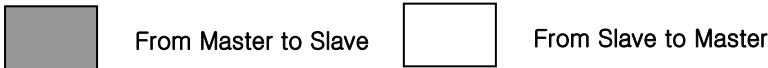

7.9 I²C timing diagram

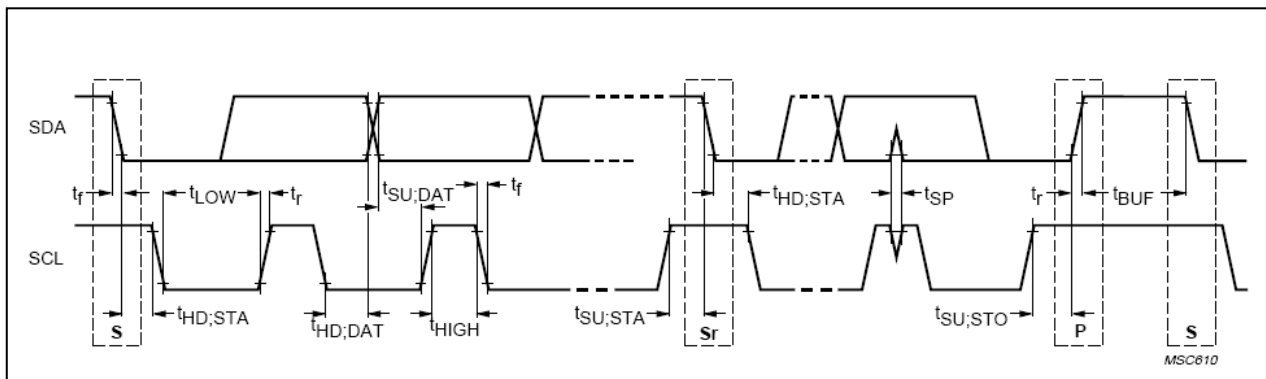

PARAMETER	SYMBOL	100kbps		400kbps		UNIT
		MIN.	MAX.	MIN.	MAX.	
Hold time (repeated)START condition.	tHD;STA	4.0	-	0.6	-	us
LOW period of the SCL clock	tLOW	4.7	-	1.3	-	us
HIGH period of the SCL clock	tHIGH	4.0	-	0.6	-	us
Set-up time for a repeated START condition	tSU;STA	4.7	-	0.6	-	us
Data hold time	tHD;DAT	1.0	-	-	-	us
Data set-up time	tSU;DAT	250	-	100	-	ns
Rise time of both SDA and SCL signals	tr	-	1000	20	300	ns
Fall time of both SDA and SCL signals	tf	-	300	20	300	ns
Set-up time for STOP condition	tSU;STO	4.0	-	0.6	-	us
Bus free time between a STOP and START condition	tBUF	4.7	-	1.3	-	us
Noise margin at the LOW level for each connected device	VnL	0.1VDD	-	0.1VDD	-	V
Noise margin at the HIGH level for each connected device	VnH	0.2VDD	-	0.2VDD	-	V
Input Low level				0	VDD*0.2	V
Input High level				VDD*0.8	VDD	V

ANMG08 (8-CH Auto Sensitivity Calibration Capacitive Touch Sensor)

8 ANMG08 control register list

◀ Note 1 : The unused bits (defined as reserved), in I2C register must be kept to the reset value or refer to the details.

◀ Note 2 : ANMG08 has the special function registers (not be published) that are useful to improve the noise immunity from the CS, RF and so on. And these registers must be kept to the reset value except the case our company recommended. Please refer to the application note if any noise (CS, RF and etc) problem is issued.

8.1 I²C Register Map

Name	Addr (Hex)	Reset Value (Bin)	Bit name of each bytes								
			Bit7	Bit6	Bit5	Bit4	Bit3	Bit2	Bit1	Bit0	
ch_enable /soft_rst	01H	1111 1111	ch8_en	ch7_en	ch6_en	ch5_en	ch4_en	ch3_en	ch2_en	ch1_en	
i2c_id	06H	0100 1000	i2c_id								wr_bit
output	2AH	Read only	o_ch8	o_ch7	o_ch6	o_ch5	o_ch4	o_ch3	o_ch2	o_ch1	
clock_ctrl	34H	0000 0110	init_cal_opt			Reserved		clk_sel		rb_sel	
global_ctrl1	36H	0100 1100	response_off_ctrl				response_ctrl		bf_mode	software_rst	
state_count	37H	1111 1111	1	1	1	cal_pre_scaler					
global_ctrl2	38H	1011 1100	imp_sel	sin_multi_mod e	cal_hold_time			Reserved	clk_off		
sensitivity1	39H	0001 1100	sensitivity01								
sensitivity2	3AH	0001 1100	sensitivity02								
sensitivity3	3BH	0001 1100	sensitivity03								
sensitivity4	3CH	0001 1100	sensitivity04								
sensitivity5	3DH	0001 1100	sensitivity05								
sensitivity6	3EH	0001 1100	sensitivity06								
sensitivity7	3FH	0001 1100	sensitivity07								
sensitivity8	40H	0001 1100	sensitivity08								
cal_speed	41H	0110 0110	rnd_bf_up		rnd_bf_down		sen_bf_up		sen_bf_down		
cal_BS_spe ed	42H	0110 0110	rnd_bs_up		rnd_bs_down		sen_bs_up		sen_bs_down		
PWM_ctrl1	43H	0000 0000	pwm_d2				pwm_d1				
PWM_ctrl2	44H	0000 0000	pwm_d4				pwm_d3				
PWM_ctrl3	45H	0000 0000	pwm_d6				pwm_d5				
PWM_ctrl4	46H	0000 0000	pwm_d8				pwm_d7				
port_mode	4FH	0000 0000	pmod_d8	pmod_d7	pmod_d6	pmod_d5	pmod_d4	pmod_d3	pmod_d2	pmod_d1	
rd_ch_H1	50H	Read only	rd_ch_H1								
rd_ch_L1	51H		-	-	-	-	-	-	-	rd_ch_L1	
Percent_H	52H		touch_percent[24:17]								
Percent_M	53H		touch_percent[16:9]								
Percent_L	54H		touch_percent[8:1]								
rd_ch_H2	56H		rd_ch_H2								
rd_ch_L2	57H		-	-	-	-	-	-	-	rd_ch_L2	

ANMG08 (8-CH Auto Sensitivity Calibration Capacitive Touch Sensor)

8.2 Details

8.2.1 Channel enable / reset register

Type: R/W

Address	Register Name	Bit7	Bit6	Bit5	Bit4	Bit3	Bit2	Bit1	Bit0
01h	ch_enable /soft_rst	ch8_en	ch7_en	ch6_en	ch5_en	ch4_en	ch3_en	ch2_en	ch1_en

Description

Enable, disable and reset of each channel control register.

Bit name	Reset value	Function
chx_en	1	Channel enable / disable and Channel reset (chx_en is control bit for CSx channel) + 0 : Channel disable and sensing channel reset + 1 : Channel enable

8.2.2 I²C address of ANMG08

Type: R/W

Address	Register Name	Bit7	Bit6	Bit5	Bit4	Bit3	Bit2	Bit1	Bit0
06h	i2c_id	i2c_id							wr_bit

Description

Chip address of ANMG08 control register.

Bit name	Reset value	Function
wr_bit	0	Write/Read address selection - 0 : Write address, 1 : Read address
i2c_id	0100100	Chip address of ANMG08.

8.2.3 Output data

Type: R

Address	Register Name	Bit7	Bit6	Bit5	Bit4	Bit3	Bit2	Bit1	Bit0
2Ah	output	o_ch8	o_ch7	o_ch6	o_ch5	o_ch4	o_ch3	o_ch2	o_ch1

Description

The output data register from channel 1 to channel 8.

Bit name	Reset value	Function
o_chx	Read only	o_chx is output bit for CSx channel + 0 : No touch detected + 1 : Touch detected

ANMG08 (8-CH Auto Sensitivity Calibration Capacitive Touch Sensor)

8.2.4 Clock control register

Type: R/W

Address	Register Name	Bit7	Bit6	Bit5	Bit4	Bit3	Bit2	Bit1	Bit0
34h	clock_ctrl	init_cal_opt			Reserved	clk_sel		rb_sel	

Description

This register controls the global options of ANMG08

The reserved bits, [Bit4] of the register address 34h, is recommended that you set to '0'.

Bit name	Reset value	Function
rb_sel ⁸	10	ANMG08 provides three internal calibration speeds with this register. <ul style="list-style-type: none"> + 00, 01 : Fast + 10 : Normal + 11 : Slow
clk_sel	01	ANMG08 provides four internal calibration speeds with this register. <ul style="list-style-type: none"> + 00 : Fast + 01 : Normal + 10 : Slow + 11 : Slowest
init_cal_opt	000	To control the initial BF time. <ul style="list-style-type: none"> + (init_cal_opt[2:0]+1) * 320 *1-Period⁹ (ms)

8.2.5 Global option control register 1

Type: R/W

Address	Register Name	Bit7	Bit6	Bit5	Bit4	Bit3	Bit2	Bit1	Bit0
36h	global_ctrl1	response_off_ctrl			response_ctrl			bf_mode	software_rst

Description

This register controls the global options of ANMG08

Bit name	Reset value	Function
software_rst	0	Software reset control bit. Reset the data of all sensing channel. <ul style="list-style-type: none"> + 0 : No reset + 1 : Reset
bf_mode	0	Operation mode selection <ul style="list-style-type: none"> ● 0 : Normal mode ● 1 : BF mode
response_ctrl	011	Numbers of continuous touch detections for touch decision. <ul style="list-style-type: none"> + response_ctrl[2:0] + 1 (Maximum time : 7)
response_off_ctrl	010	Numbers of continuous touch off detections for touch off decision. <ul style="list-style-type: none"> + response_off_ctrl[2:0] + 1 (Maximum time : 7)

⁸ The rb_sel register changes the sensitivity of all channels slightly. Slow setting tend to be more sensitive. Fast setting tend to be more insensitive.

⁹ 1-Period means that the time from the current sensing burst to the next sensing burst. And the number, 320 is the time control constant value.

ANMG08 (8-CH Auto Sensitivity Calibration Capacitive Touch Sensor)

8.2.6 State count control register

Type: R/W

Address	Register Name	Bit7	Bit6	Bit5	Bit4	Bit3	Bit2	Bit1	Bit0
37h	state_count	1	1	1	cal_pre_scaler				

Description

Register to set the pre-scaler for the calibration speed.

Bit name	Reset value	Function
cal_pre_scaler	1 1111	The pre-scaler for the calibration speed. + cal_pre_scaler[4:0] *1-Period (ms)

8.2.7 Global option control register 2

Type: R/W

Address	Register Name	Bit7	Bit6	Bit5	Bit4	Bit3	Bit2	Bit1	Bit0
38h	global_ctrl2	imp_sel	sin_multi_mode	cal_hold_time			Reserved	clk_off	

Description

This register controls the global options of ANMG08.

The reserved bits, [Bit1] of the register address 38h, is recommended that you set to '0'.

Bit name	Reset value	Function
clk_off	0	System clock off control bit. + 0 : Not clock off + 1 : Clock off
cal_hold_time	1111	Output expiration Time control. + cal_hold_time[3:0] * 512 ¹⁰ * 1-Period (ms) + The output expiration time is infinite when the data of the "cal_hold_time" is "0000".
sin_multi_mode	0	Single/Multi output operation mode selection bit. + 0 : Multi output mode + 1 : Single output mode
imp_sel	1	Impedance of the sensing wire of all channels control bit. + 0 : High impedance + 1 : Low impedance except sensing period.

¹⁰ The number, 512 is the time control constant value.

ANMG08 (8-CH Auto Sensitivity Calibration Capacitive Touch Sensor)

8.2.8 Sensitivity register

Type: R/W

Address	Register Name	Bit7	Bit6	Bit5	Bit4	Bit3	Bit2	Bit1	Bit0
39H	sensitivity1								sensitivity01
3AH	sensitivity2								sensitivity02
3BH	sensitivity3								sensitivity03
3CH	sensitivity4								sensitivity04
3DH	sensitivity5								sensitivity05
3EH	sensitivity6								sensitivity06
3FH	sensitivity7								sensitivity07
40H	sensitivity8								sensitivity08

Description

The sensitivity of channel is possible to adjust by the “sensitivity1~sensitivity8” registers. The following table show detail information of sensitivity.

The lower value of these register ANMG08 has, the higher sensitivity ANMG08 has. And if user want to set higher sensitivity over 0.7%, it is recommended to refer to the application note.

Bit name	Reset value	Function
sensitivity0x	0001 1100	Sensitivities of each channel. Sensitivity of CSx channel: {(sensitivity0x[7:0] x 0.025)} (%).

8.2.9 Calibration speed control register

Type: R/W

Address	Register Name	Bit7	Bit6	Bit5	Bit4	Bit3	Bit2	Bit1	Bit0
41H	cal_speed								

Description

Calibration speed can be controlled by this ‘cal_speed’ register at BF mode.

Bit name	Reset value	Function
sen_bf_down	10	Sense channel down calibration speed at BF mode control bits. <ul style="list-style-type: none"> 00 : Fastest 01 : Fast 10 : Normal 11 : Slow
sen_bf_up	01	Sense channel up calibration speed at BF mode control bits. <ul style="list-style-type: none"> 00 : Fastest 01 : Fast 10 : Normal 11 : Slow
rnd_bf_down	10	RND channel down calibration speed at BF mode control bits. <ul style="list-style-type: none"> 00 : Fastest 01 : Fast 10 : Normal 11 : Slow
rnd_bf_up	01	RND channel up calibration speed at BF mode control bits. <ul style="list-style-type: none"> 00 : Fastest 01 : Fast 10 : Normal 11 : Slow

ANMG08 (8-CH Auto Sensitivity Calibration Capacitive Touch Sensor)

8.2.10 Calibration speed control register at BS mode

Type: R/W

Address	Register Name	Bit7	Bit6	Bit5	Bit4	Bit3	Bit2	Bit1	Bit0
42H	cal_BS_speed	rnd_bs_up		rnd_bs_down		sen_bs_up		sen_bs_down	

Description

Calibration speed can be controlled by this 'cal_BS_speed' register at BS mode.

Bit name	Reset value	Function
sen_bs_down	10	Sense channel down calibration speed at BS mode control bits. 🚦 00 : Fastest 🚦 01 : Fast 🚦 10 : Normal 🚦 11 : Slow
sen_bs_up	01	Sense channel up calibration speed at BS mode control bits. 🚦 00 : Fastest 🚦 01 : Fast 🚦 10 : Normal 🚦 11 : Slow
rnd_bs_down	10	RND channel down calibration speed at BS mode control bits. 🚦 00 : Fastest 🚦 01 : Fast 🚦 10 : Normal 🚦 11 : Slow
rnd_bs_up	01	RND channel up calibration speed at BS mode control bits. 🚦 00 : Fastest 🚦 01 : Fast 🚦 10 : Normal 🚦 11 : Slow

8.2.11 LED luminance control register

Type: R/W

Address	Register Name	Bit7	Bit6	Bit5	Bit4	Bit3	Bit2	Bit1	Bit0
43h	PWM_ctrl1	pwm_d2				pwm_d1			
44h	PWM_ctrl2	pwm_d4				pwm_d3			
45h	PWM_ctrl3	pwm_d6				pwm_d5			
46h	PWM_ctrl4	pwm_d8				pwm_d7			

Description

LED luminance can be controlled by "PWM_ctrlx" register.

Bit name	Reset value	Function
pwm_dx	0000	The LED PWM control bits of Dx port. 🚦 0000 : The minimum low duty 🚦 1111 : The maximum low duty

ANMG08 (8-CH Auto Sensitivity Calibration Capacitive Touch Sensor)

8.2.12 Port mode control register

Type: R/W

Address	Register Name	Bit7	Bit6	Bit5	Bit4	Bit3	Bit2	Bit1	Bit0
4Fh	port_mode	pmod_d 8	pmod_d 7	pmod_d 6	pmod_d 5	pmod_d 4	pmod_d 3	pmod_d 2	pmod_d 1

Description

This register controls the mode of output port.

Bit name	Reset value	Function
pmod_dx	0	Select the output port operation mode of each channel. 0 : Parallel output mode 1 : LED drive mode

ANMG08 (8-CH Auto Sensitivity Calibration Capacitive Touch Sensor)

8.2.13 Sense, reference count read register

Type: R

Address	Register Name	Bit7	Bit6	Bit5	Bit4	Bit3	Bit2	Bit1	Bit0
50h	rd_ch_H1	rd_ch_H1							
51h	rd_ch_L1	-	-	-	-	-	-	-	rd_ch_L1
52h	Percent_H	touch_percent[25:18]							
53h	Percent_M	touch_percent[17:10]							
54h	Percent_L	touch_percent[9:2]							
56h	rd_ch_H2	rd_ch_H2							
57h	rd_ch_L2	-	-	-	-	-	-	-	rd_ch_L2

Description

ANMG08 provides the special function to read sense count of each channels or reference count.

Bit name	Reset value	Function
rd_ch_H1	Read only	Read channel indication register. 🚩 00000001 : - 🚩 00000010 : R.N.D channel 🚩 00000100 : CS1 channel 🚩 00001000 : CS2 channel 🚩 00010000 : CS3 channel 🚩 00100000 : CS4 channel 🚩 01000000 : CS5 channel 🚩 10000000 : CS6 channel
rd_ch_L1	Read only	Read channel indication register. 🚩 01 : CS7 channel 🚩 10 : CS8 channel
touch_percent[24:17]	Read only	The percent data of RND channel and sense channels. 🚩 [25:18] bits of the touch percent data.
touch_percent[16:9]	Read only	The percent data of RND channel and sense channels. 🚩 [17:10] bits of the touch percent data.
touch_percent[8:1]	Read only	The percent data of RND channel and sense channels. 🚩 [9:2] bits of the touch percent data.
rd_ch_H2	Read only	Read channel indication register. 🚩 00000001 : - 🚩 00000010 : R.N.D channel 🚩 00000100 : CS1 channel 🚩 00001000 : CS2 channel 🚩 00010000 : CS3 channel 🚩 00100000 : CS4 channel 🚩 01000000 : CS5 channel 🚩 10000000 : CS6 channel
rd_ch_L2	Read only	Read channel indication register. 🚩 01 : CS7 channel 🚩 10 : CS8 channel

9 Recommended Circuit Diagram

9.1 ANMG08PL (24 SSOP)

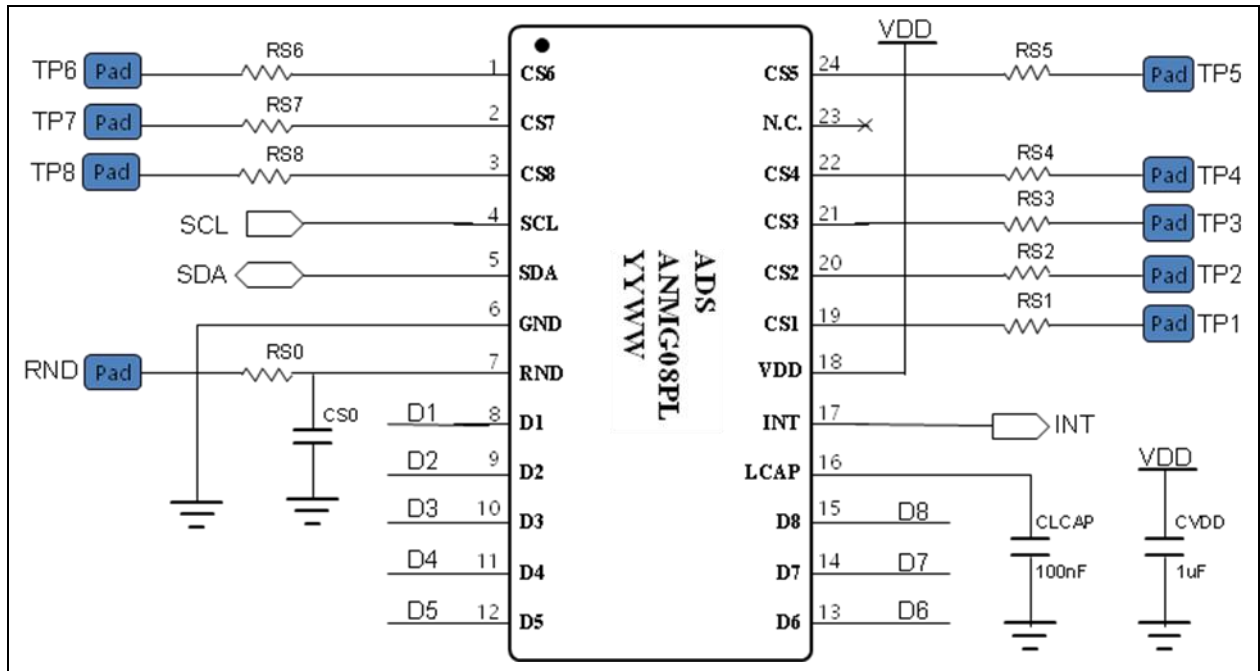

ANMG08PL (24 SSOP) Application Example Circuit

- ✓ ANMG08PL is reset by internal reset circuit. VDD voltage rising time should be shorter than 100msec for proper operation.
- ✓ LCAP voltage should be bigger than 'minimum digital operating voltage' for normal reset operation when VDD voltage arrived at reset voltage. (# Minimum digital operating voltage : 0.9~1.4V)
- ✓ Normally, RND's capacitance have to be similar to capacitance of other channels(CS1~CS8). Therefore, RND pin have to connect with a proper capacitor(CS0). Additionally, in radio frequency noise environment, RND pin must form a pattern line on PCB.
- ✓ The VDD periodic voltage ripple over 50mV and the ripple frequency is lower than 10 kHz can cause wrong sensitivity calibration. To prevent above problem, power (VDD, GND) line of touch circuit should be separated from other circuit. Especially LED driver power line or digital switching circuit power line certainly should be treated to be separated from touch circuit.
- ✓ The CS patterns also should be routed as short as possible and the width of line might be about 0.25mm.
- ✓ Parallel capacitor of CS pin could be useful in case detail sensitivity mediation is required such as for complementation sensitivity difference between channels.
- ✓ Serial connection resistor of CS pins may be used to avoid mal-function from external surge and ESD and the closer to IC(ANMG08PL), the stronger immunity against mal-function and ESD is.
- ✓ The CVDD capacitor that is between VDD and GND is an obligation.
- ✓ CVDD and CLCAP capacitors should be located as close as possible from ANMG08PL.
- ✓ The CS pattern routing should be formed by bottom metal (opposite metal of touch PAD).
- ✓ The empty space of PCB must be filled with GND pattern to strengthen GND pattern and to prevent external noise from interfere with sensing frequency.
- ✓ If VDD rising speed is very fast, about 200nF capacitor between VDD and LCAP is necessary for normal reset operation.

ANMG08 (8-CH Auto Sensitivity Calibration Capacitive Touch Sensor)

9.2 Example – Power Line Split Strategy PCB Layout

A. Not split power Line (Bad power line design)

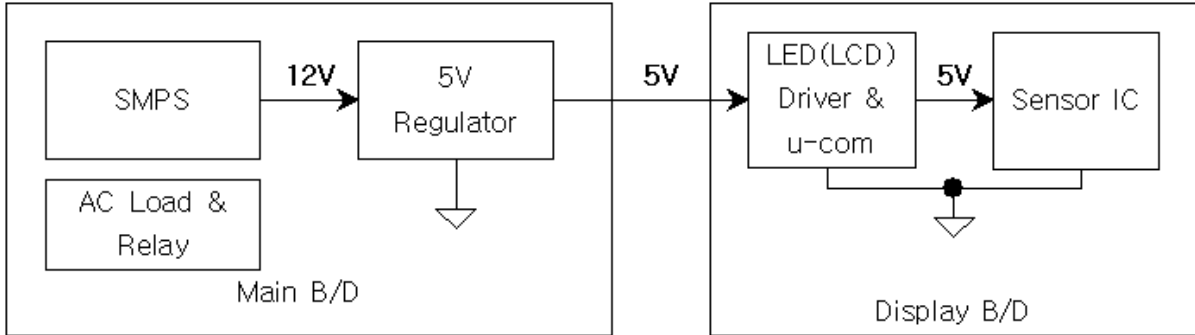

- ✓ The noise that is generated by AC load or relay can be loaded at 5V power line.
- ✓ A big inductance might be appeared in case of the connection line between main board and display board is too long, moreover the voltage ripple could be generated by LED (LCD) display driver at VDD (5V).

B. Split power Line (One 5V regulator used) – Recommended

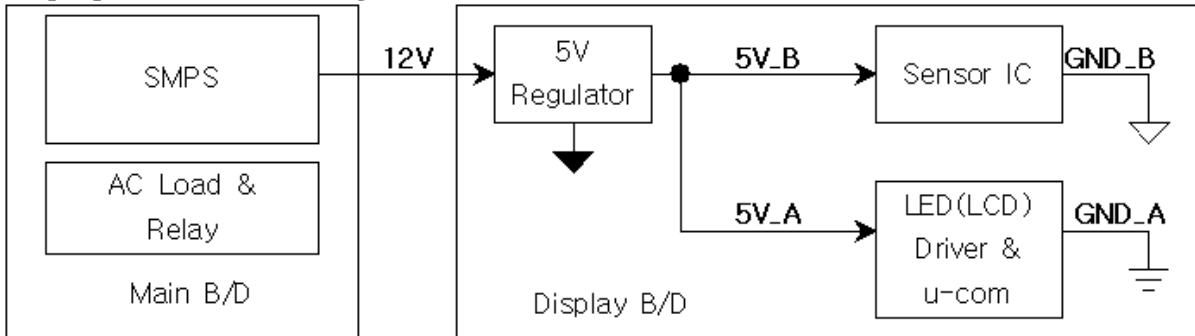

C. Split power Line (Separated 5V regulator used) – Strongly recommended

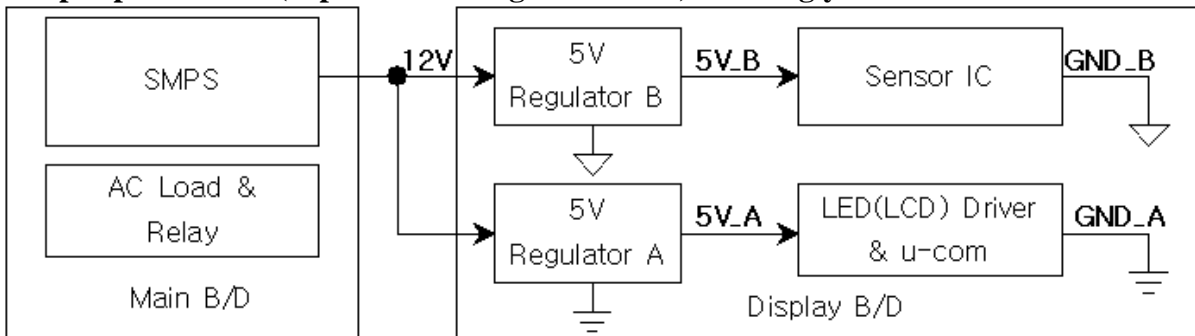

10 MECHANICAL DRAWING

10.1 Mechanical Drawing of ANMG08PL (24 SSOP)

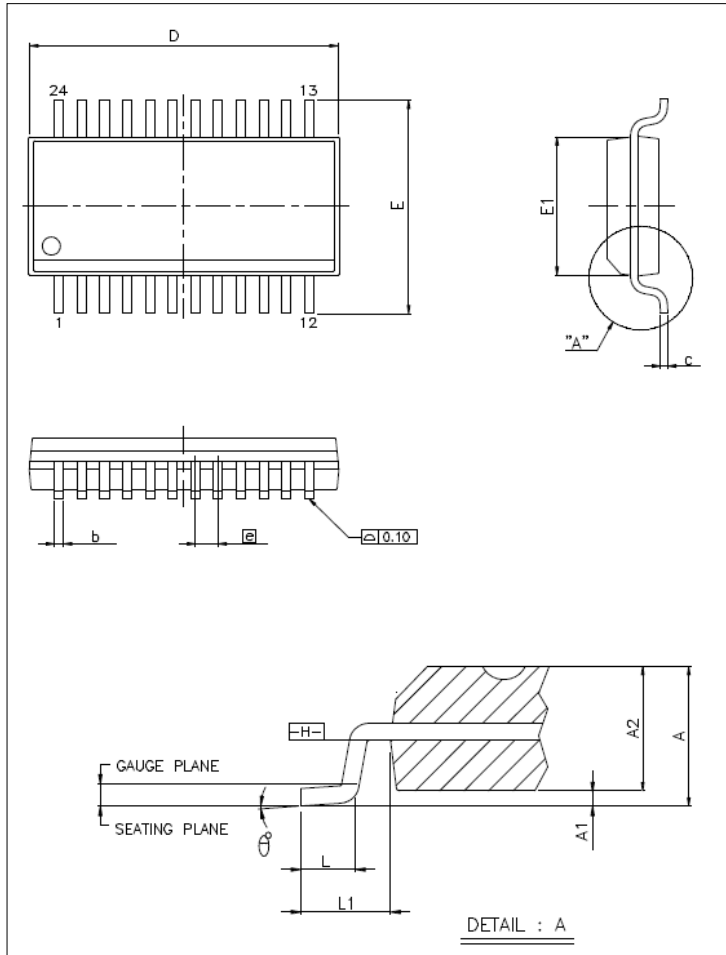

SYMBOLS	MIN.	NOM.	MAX.
A	1.35	1.63	1.75
A1	0.10	0.15	0.25
A2	—	—	1.50
D	8.56	8.66	8.74
E	5.79	5.99	6.20
E1	3.81	3.91	3.99
b	0.20	—	0.30
c	0.18	—	0.25
[e]	0.64 BASIC		
L	0.41	0.64	1.27
L1	1.04 BASIC		
θ°	0°	—	8°

UNIT : MM

NOTES:

1. JEDEC OUTLINE : MO-137 AE
2. DIMENSION D DOES NOT INCLUDE MOLD PROTRUSIONS OR GATE BURRS. MOLD PROTRUSIONS AND GATE BURRS SHALL NOT EXCEED 0.15 MM PER SIDE. DIMENSION E1 DOES NOT INCLUDE INTERLEAD MOLD PROTRUSIONS. INTERLEAD MOLD PROTRUSIONS SHALL NOT EXCEED 0.25 MM PER SIDE.
3. DIMENSION b DOES NOT INCLUDE DAMBAR PROTRUSION/INTRUSION. ALLOWABLE DAMBAR PROTRUSION SHALL BE 0.10 MM TOTAL IN EXCESS OF b DIMENSION AT MAXIMUM MATERIAL CONDITION. DAMBAR INTRUSION SHALL NOT REDUCE DIMENSION b BY MORE THAN 0.05 MM AT LEAST.

ADSemiconductor®

" Free from Common Mode Noise "

ANMG08 (8-CH Auto Sensitivity Calibration Capacitive Touch Sensor)

NOTES:

LIFE SUPPORT POLICY

AD SEMICONDUCTOR'S PRODUCTS ARE NOT AUTHORIZED FOR USE AS CRITICAL COMPONENTS IN LIFE SUPPORT DEVICES OR SYSTEMS WITHOUT THE EXPRESS WRITTEN APPROVAL OF THE PRESIDENT AND GENERAL COUNSEL OF AD SEMICONDUCTOR CORPORATION

The ADS logo is a registered trademark of ADSemiconductor

© 2006 ADSemiconductor – All Rights Reserved

www.adsemicon.com
www.adsemicon.co.kr